

Hoto

Flashlight

QWSDT003, 280lm, USB-C

User Manual

01 Product Overview

Thanks for using HOTO Flashlight Fit.
Read this manual carefully before use, and retain it for future reference.

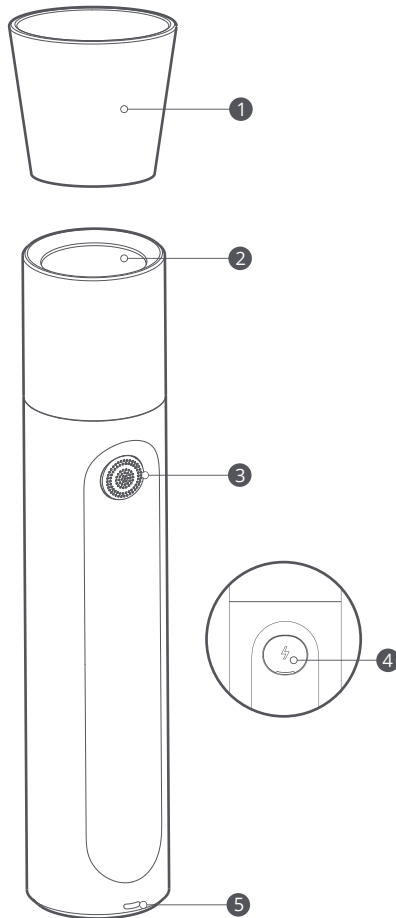

- ① Cover
- ② Lamp cap
- ③ Switch button/Battery indicator light
- ④ Waterproof plug for charging port
- ⑤ Lanyard hole

02 How to Use

Flashlight mode

- Press the switch button to turn on or turn off the flashlight;
- The battery indicator light is on when the flashlight is powered-on;
- Long press the switch button to dim from 100% to 5%. When the light reaches the lowest or highest brightness, it will flash twice.

Strobe light/SOS mode

- Two rapid clicks on the power button directly switches the flashlight to strobe light mode.
- Press the power button twice again and the flashlight will switch to SOS mode. In strobe light mode or SOS mode, a short press on the power button deactivates the mode.

Battery status indicator

- While operating:
Battery level \leq 30%: Red light;
Battery level 30%-60%: Orange light;
Battery level \geq 60%: Green light;
While charging:
• During the charging process, the indicator shows a permanent red light. When it is charged to 100%, the light will turn green, and will turn off after unplugging the charging cable.

When the product is being charged, all functions can be used normally.

This product is equipped with a Type-C charging cable.

03 Warning

Safety precautions

- For proper use
Please follow the instructions in this User Guide to use this product properly.
- Repair services
Do not disassemble this product. In order to avoid safety accidents, only authorized personnel are allowed to repair this product.
- Charging instructions
 1. This product can only be charged with a charger that meets its charging parameters.
 2. If the status indicator light does not work properly during charging because this product has not been used for a long period of time, please charge it for 30 minutes for observation.
- Instructions for use
 1. This product can emit strong light. Please keep direct rays of light away from the eyes of people and animals and the lens of optical equipment.
 2. To reduce the risk of injury, children should be accompanied by their parents when using this product.
 3. To reduce the risk of electric shock, do not place this product in water or other liquids.
 4. Do not place or store this product where it may fall into the bathtub or sink.

Warnings

1. Damages caused by using a charger with unfitting parameters for charging is not covered by the warranty, and it may lead to other hazards.
2. If battery temperature of this product reaches 45°C, the charging protection function will be triggered, and the charging will be discontinued. The recommended ambient temperature for charging is 0-30°C.

Battery safety warnings

- Do not open or shred the battery.
- Do not expose the battery to heat sources or flames. Do not store the battery under direct sunlight.
- Do not perform mechanical shocks to the battery.
- If the battery accidentally leaks, avoid direct contact of leaking liquid with skin or eyes. In case of contact, it is recommended to rinse with abundant water.
- Charge the battery before first use.
- After long-term storage, the battery needs to be charged and discharged several times to obtain the best battery performance.
- Battery performance is best when used at ordinary temperature ($20\pm 5^{\circ}\text{C}$), its performance is the best.
- The battery must be removed before this product is disposed of.
- Before removing the battery, the power of this product must be cut off.
- Please recycle and dispose of the battery in an environmentally correct manner.



All products bearing this symbol are waste electrical and electronic equipment (WEEE as in  directive 2012/19/EU) which should not be mixed with unsorted household waste. Instead, you should protect human health and the environment by handing over your waste equipment to a designated collection point for the recycling of waste electrical and electronic equipment, appointed by the government or local authorities. Correct disposal and recycling will help prevent potential negative consequences to the environment and human health. Please contact the installer or local authorities for more information about the location as well as terms and conditions of such collection points.



We Shanghai HOTO Technology Co., Ltd., hereby, declares that this equipment is in compliance with the applicable Directives and European Norms, and amendments.

Federal Communications Commission Supplier's Declaration of Conformity

This supplier's declaration of conformity is hereby for
Product: HOTO Flashlight Fit
Model Number(s): QWSDT003
Brand/Trade: HOTO

We declare that the above mentioned device has been tested and found in compliance with CFR 47 Part 15 Regulation.

This device complies with part 15 of the FCC Rules. Operation is subject to the following two conditions: (1) This device may not cause harmful interference, and (2) this device must accept any interference received, including interference that may cause undesired operation.

Note: This equipment has been tested and found to comply with the limits for a Class B digital device, pursuant to part 15 of the FCC Rules. These limits are designed to provide reasonable protection against harmful interference in a residential installation. This equipment generates, uses and can radiate radio frequency energy and, if not installed and used in accordance with the instructions, may cause harmful interference to radio communications. However, there is no guarantee that interference will not occur in a particular installation. If this equipment does cause harmful interference to radio or television reception, which can be determined by turning the equipment off and on, the user is encouraged to try to correct the interference by one or more of the following measures:

- Reorient or relocate the receiving antenna.
- Increase the separation between the equipment and receiver.
- Connect the equipment into an outlet on a circuit different from that to which the receiver is connected.
- Consult the dealer or an experienced radio/TV technician for help.

Representative of Responsible Party for SDoC
Company: Shanghai HOTO Technology Co., Ltd.
Address: Building 45, No.50 Moganshan Road, Putuo District, Shanghai, China
Country: China
Telephone No.: 400-021-8696

Troubleshooting

Issues	Possible Causes	Solutions
Pressing the main power button doesn't light up any light, and battery indicator shows a flashing red light.	The lithium battery runs low	Charging
The battery indicator light is not on during charging	1. The charging cable is not plugged in properly, or the charging cable is not the designated one; 2. The ambient temperature for charging is below 0°C or above 45°C	1. Please use the designated charging cable and the 5V power adapter; 2. Charge this product in adequate environmental temperatures 0-45°C

04 Specifications

Model: QWSDT003	Battery Type: Lithium-ion battery
Item Dimensions: $\varphi 30 \times 145$ mm	Rated Capacity: 1500 mAh
Net Weight: 146 g	Rated Voltage: 3.6 V \approx
Input: 5 V \approx 1 A	Charging Time: Approx. 240 min
	Waterproof IP rating: IP55

Lighting parameters

	High	Low
Brightness	280lm	20lm
Battery life	3h	24h
Illumination distance	200m	10m

Manufacturer: Shanghai HOTO Technology Co., Ltd.
Address: Building 45, No. 50 Moganshan Rd, Putuo District, Shanghai, PRC, 200060.

DECLARATION OF CONFORMITY



EU Declaration of Conformity
We

Shanghai HOTO Technology Co., Ltd.

Declare that the product:
HOTO Flashlight Fit / QWSDT003

Complies with the essential health and safety
requirements of the following directives:

2014/35/EU The Low Voltage Directive

References to the following harmonized standard were
made:

EN 60598-1:2008

EN 60598-2-4:2018

2014/30/EU Electromagnetic Compatibility directive

References to the following harmonized standard were
made:

EN 55015:2019

EN 61547: 2009

EN 62471:2008

2011/65/EU+ (EU) 2015/863 Restrictions of the Use of
Certain Hazardous Substances in Electrical and
Electronic Equipment

Authorised signatory and technical file holder:
Shanghai HOTO Technology Co., Ltd.
Building 45, No.50 Moganshan Road, Shanghai, China